

Model 772 pH and DO Analyzer

Features :

- Multiple measurements. (pH/ORP, pH temperature, DO%, DO ppm, DO nA, DO Temperature)
- Accepts conventional combinational pH or ORP sensor.
- Accepts Pt 1000 RTD, Pt 100 RTD, or NTC 300 ohm thermistor pH temperature compensators.
- Accepts DO sensor along with 22K Ohm thermistor for temp. compensation.
- Large backlit LCD readout.
- Two isolated 4-20 mA analog outputs, selectable.
- Menu - guided operation.
- Universal-mount ½ DIN case.
- Passcode – protected access.
- Electrical Protection.
- Simple interactive diagnostics.



■ Specifications

Display Graphic dot matrix LCD, 128 x 64 pixels with LED backlighting; ½ inch (13 mm) main character height; 1/8 inch (3 mm) auxiliary information character height; menu screens contain up to six text lines

Measurement	Selectable Ranges
pH	0.00 to 14.00 pH
ORP	-2000 to +2000 mV
pH Temperature	-10.0 to +140.0° C
DO%	0 - 300.0%
DO ppm	0 - 30.00 ppm
DO Temperature	10° C - 110° C
mA Outputs (#1 and #2)	4.00 - 20.00 mA

Ambient Conditions -30 to + 50°C; 0-100% relative humidity, non-condensing

Relays

Types/Outputs Two electromechanical relays; SPDT (Form C) Contacts; U. L. rated 5A 115/230 VAC, 5A@ 30 VDC resistive

Functional Modes Each relay (A, B) can be assigned to be driven by the measured pH (or ORP) or pH temperature or DO% or DO temperature.

Operating Modes Control: Settings for high/low phasing, setpoint, deadband.

Alarm: Settings for low alarm point, low alarm point deadband, high alarm point, high alarm point deadband.

Indicators Relay annunciators (A, B) indicate respective relay status.

pH Temperature Compensation Automatic (-10.0° to +140.0°C) with selection for temperature compensator (Pt 1000 ohm RTD, Pt 100 ohm RTD, or NTC 300 ohm thermistor) or manual (0.0°C to +100.0°C)

DO Temperature Compensation Automatic (-10° C to + 110° C) or Manual (0° C to 100° C).

pH Sensor-to-Analyzer Distance :

Conventional Combination
Electrode with Preamplifier 985 ft. (300 m) maximum

Conventional Combination
Electrode without Preamplifier 15 ft. (4.5 m) max. with electrode cable capacitance of less than 30 pF/foot

DO Sensor-to Analyzer Distance : 50 feet max.

Power Requirements 90-130 VAC, 50/60 Hz. (10 VA max.) or 180-260 VAC, 50/60 Hz. (10VA max.)

pH Calibration Methods:

2-point Sample Method (pH & ORP) Enter two sample value (derived by laboratory analysis or comparison reading) or two user-supplied buffer values.

1-point Sample Method (pH & ORP) Enter one sample value (derived by laboratory analysis or comparison reading), one reference solution value, or one user-supplied buffer value.

DO Calibration Methods:

2-point Sample Method (DO%) Enter zero (0.0)% and HI CAL sample value.

Outputs: Analog Two outputs (# 1 or #2) each with 0.004 mA (12-bit) resolution:

Output #1 : Isolated 4-20 mA (selectable); 600 ohms maximum load

Output #2 : Isolated 4-20 mA (selectable); 600 ohms maximum load

Note: Each output can be assigned to represent the measured pH (or ORP) or pH temperature or DO% or DO temperature. Associated values can be entered to define the endpoints at which the minimum and maximum mA output values are desired. During calibration, both outputs and relays, hold their present values.

Memory Backup (non-volatile) All user settings are retained indefinitely in memory (EEPROM)

Analyzer Performance for pH/ORP DO (Electrical, Mechanical, Analog Outputs):

Accuracy 0.5% of span

Stability 0.05% of span per 24 hours, non-cumulative

Repeatability 0.1% of span or better

Temperature Drift Zero : less than 0.03% of span per °C
 Span : less than 0.03% of span per °C

Enclosure NEMA 4X; ½ DIN Polycarbonate with two ½ inch conduit holes and two stainless steel mounting brackets.

Mounting Conf Panel, Surface and pipe mount.

Net Weight 3 lbs. (1.36 kg) approximately

Ordering Information

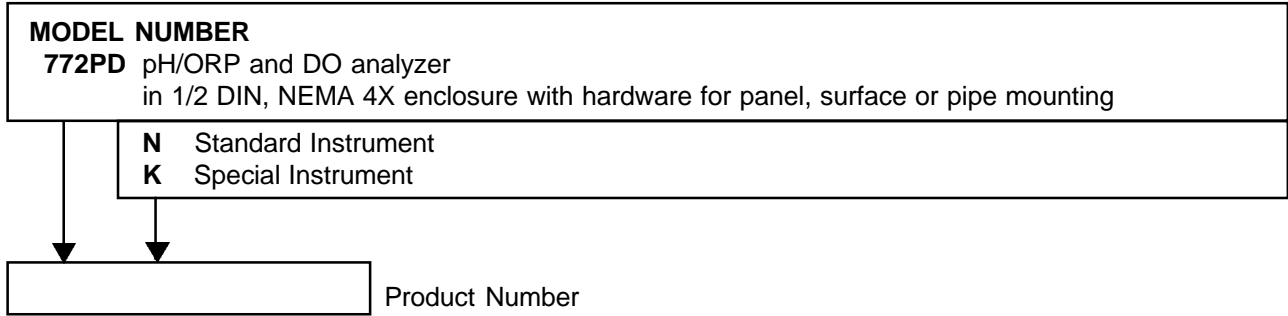

Choose one from each category

Dimensions

Inches (mm)

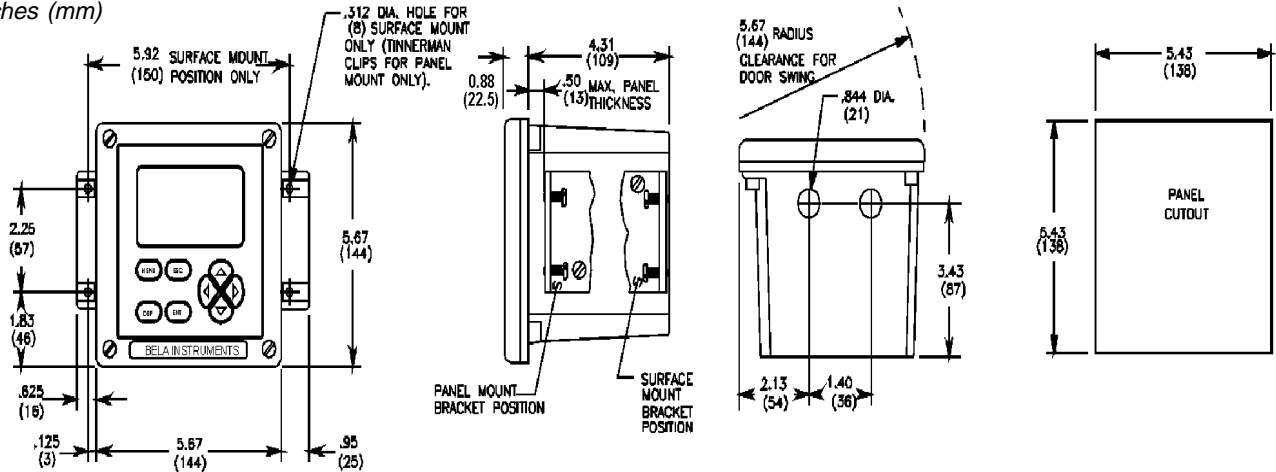

6/309, Jogani Industrial Complex, V. N. Purav Marg, Chunabhathi, Mumbai - 400022.
 Tel. : (91-22) 2524 6844/45/46, 2524 6965, 2524 1036 • Fax : (91-22) 2523 5952.
 Email : belainst@vsnl.com • Website : www.belainstruments.com

For upgradation, BI reserves the rights to alter the specifications at any time